

INTRODUCTION TO WAVEGUIDES

EEEN 566– MICROWAVE ENGINEERING

Friday, 24 January 2025

A PAIR OF CONDUCTORS IS USED TO GUIDE TEM WAVE

- **Two-wire TL**



- **Coaxial cable**



- **Microstrip**

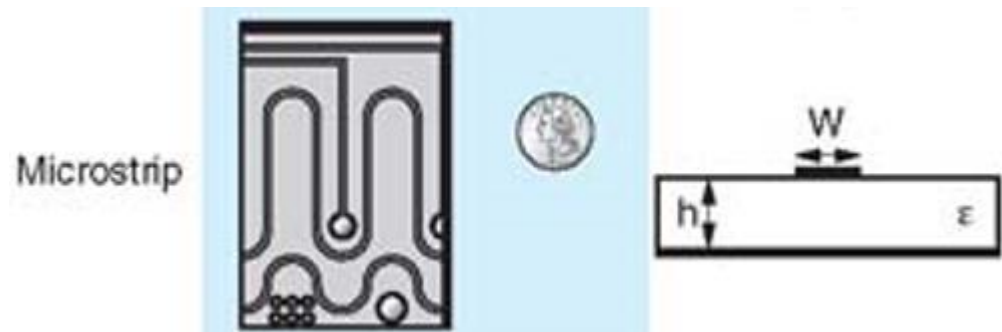

WHAT IS A WAVEGUIDE?

1. A waveguide is an electromagnetic feed line used in microwave communications, satellite earth stations and radar installations.
2. A waveguide consists of a rectangular or cylindrical metal tube or pipe. It can also be flexible.
3. The electromagnetic field propagates lengthwise.
4. They are often used with horn or dish antennas.

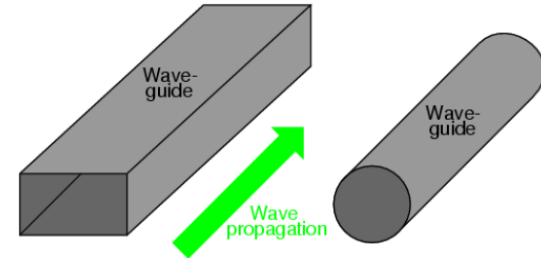

WHAT IS A WAVEGUIDE? (2)

1. **A waveguide** is a structure that guides waves, such as electromagnetic waves, light or sound waves. They enable a signal to propagate with minimal loss of energy by restricting expansion to one dimension or two.
2. **Without the physical constraint of a waveguide, signals will typically be radiated and decreased according to the inverse square law** as they expand into three-dimensional space.

GSM BTS antennas operating in 900 and 1800 MHz band

Parabolic antenna for microwave link to Base Station Controller (4 – 6 GHz)

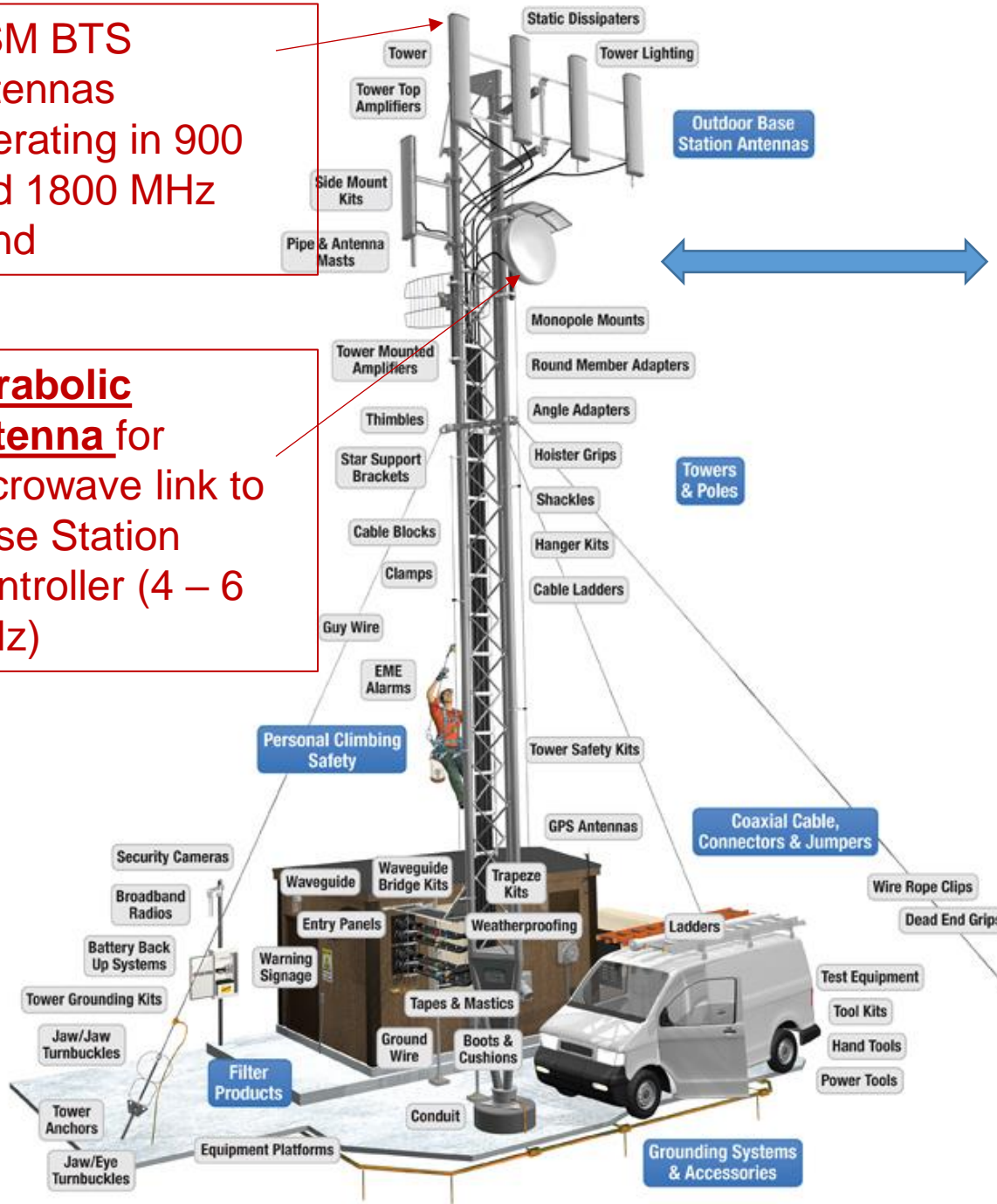

(a) Sometimes the dishes are covered to avoid dust and water collection

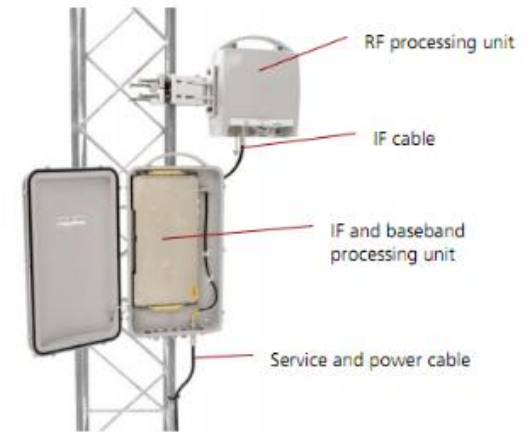

(b) For tall towers, the RF and baseband processing units are sometimes mounted high up on the tower.

HORN ANTENNAS USE WAVEGUIDES

A Horn antenna is usually a flared-out waveguide, by which the directivity is increased and the diffraction is reduced.

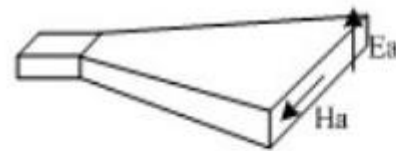
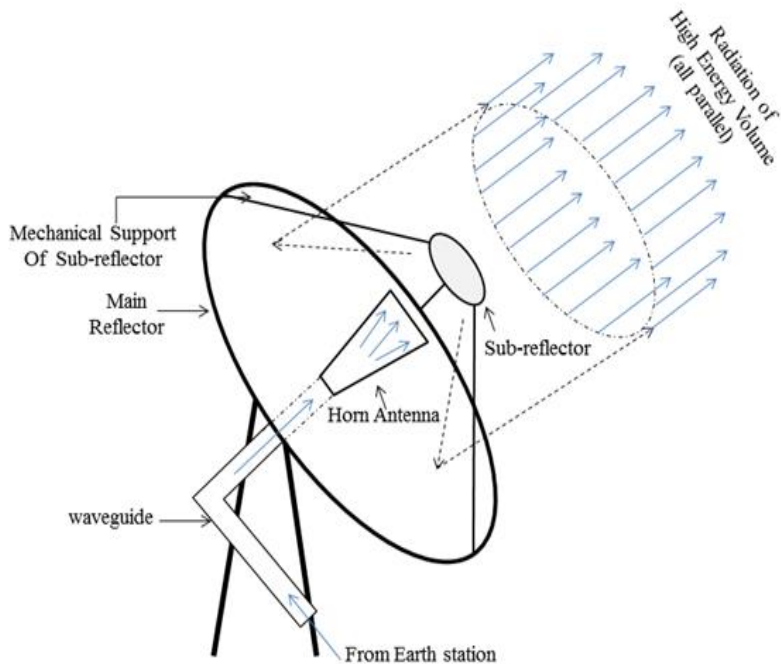

H-plane sectoral horn

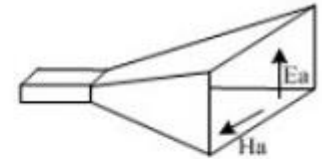

Pyramidal horn

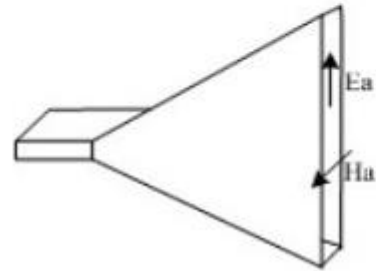

E-plane sectoral horn

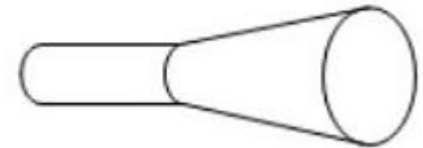

Conical Horn Antenna

BASE STATION WITH FIBER INSTEAD OF METAL WAVEGUIDE

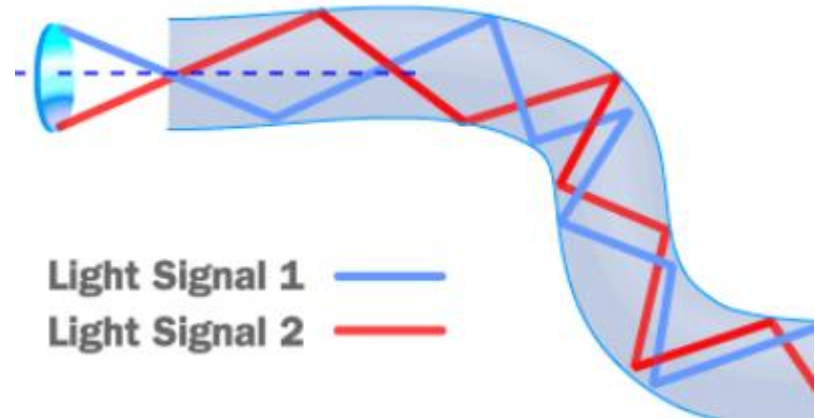
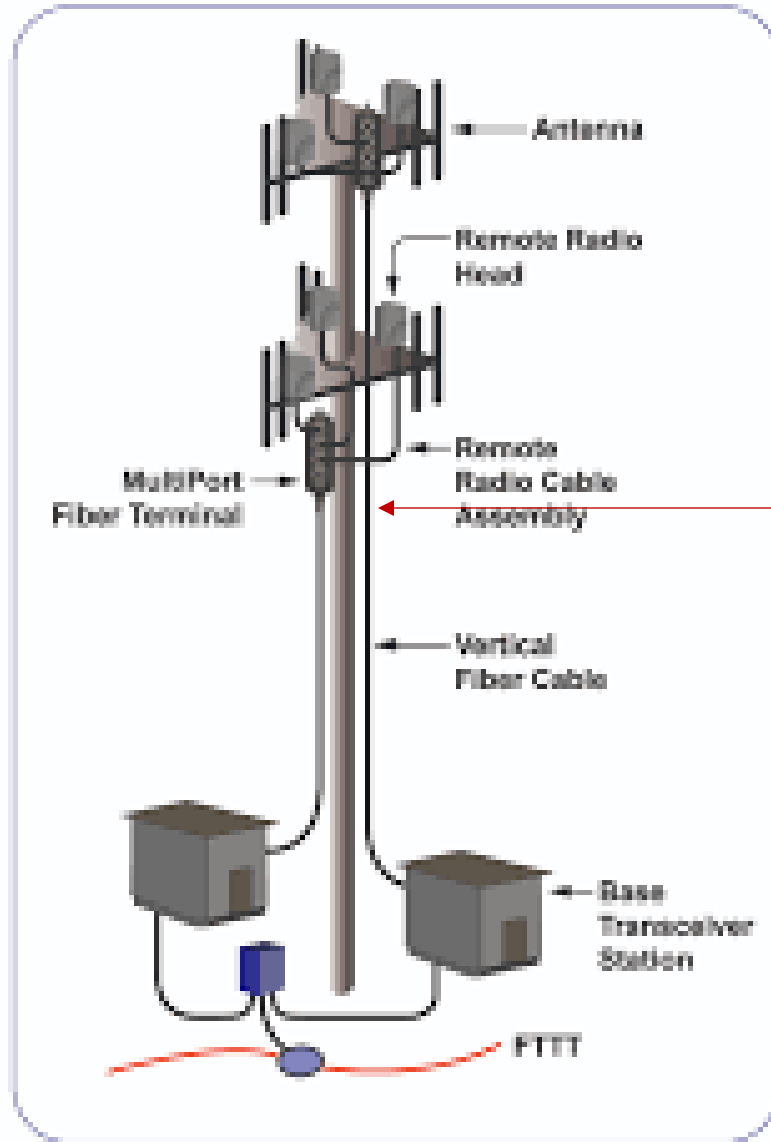

(a) Fiber Optic Cable is waveguide that guide in two dimensions and can effectively be used as flexible pipes for light.

[Coax Loss Calculator | KV5R.COM](http://KV5R.COM)

[Fiber Loss Calculator \(samm.com\)](http://samm.com)

USE THIS ONLINE CALCULATOR TO GET FIBER LOSS FOR 5m, 10m, 30m

Go to the website shown below and verify that fibre cable loss is negligible for typical telecommunication tower heights.

The screenshot shows a web browser window with the URL <https://telecom.samm.com/fiber-loss-calculator>. The calculator interface is teal and white. It has five input fields for Fiber Length (m), Fiber Mode, Core/Cladding, Wavelength, and Splice Count, and one for Connector Count. The results are displayed below the inputs.

Fiber Length (m)	Fiber Mode	Core/Cladding	Wavelength	Splice Count	Connector Count
30	Single-Mode	9/125 μm	1310 nm	1	1

Fiber Loss 0.86 dB

Theoretical Value 0.86 dB
Safety Margin Value 3.86 dB

Calculate

[Fiber Loss Calculator \(samm.com\)](https://telecom.samm.com/fiber-loss-calculator) - <https://telecom.samm.com/fiber-loss-calculator>

USE THIS ONLINE CALCULATOR TO GET CABLE LOSS FOR 5m, 10m, 30m

Go to the website provided below and verify that at microwave frequency ranges 1GHz, 10GHz, 20 GHz, ... the cable losses are very high and unacceptable for long coaxial cables.

Line Loss Calculator:

Note: Set Line Length 100 here to use the ERP Calc. Put actual line length in the ERP Calc.

Parameters:			Results:		
Line Type:	Belden 9201 RG-58	▼	Matched Loss:	16.184	dB
Line Length:	30	<input type="radio"/> Feet <input checked="" type="radio"/> Meters	SWR Loss:	0.177	dB
Frequency:	1000	MHz	Total Loss:	16.361	dB
Load SWR:	1.5	:1	Power Out:	2.311	Watts
Power In:	100	Watts	Power Loss:	98	%
<input type="button" value="Calculate"/> before using ERP Calc.					

[Coax Loss Calculator | KV5R.COM](https://kv5r.com/ham-radio/coax-loss-calculator/)

<https://kv5r.com/ham-radio/coax-loss-calculator/>

WHAT IS A WAVEGUIDE IN MICROWAVE ENGINEERING?

1. **A waveguide** is an electromagnetic feed line used in microwave communications, broadcasting, and radar installations.
2. **A waveguide** consists of a rectangular or cylindrical metal tube or pipe.
3. **Electromagnetic field propagates lengthwise in waveguides**
4. **Waveguides** are most often used with horn and dish antennas.
5. **Waveguides do not support TEM mode.**
6. **Waveguides are unable to support wave propagation below a certain frequency, termed the cutoff frequency. They therefore act as high pass filters.**

TYPES OF WAVEGUIDES

Four types of waveguides are:

1. **Rectangular Waveguide** is for high-power microwave applications but is limited in frequency range and tends to suffer from dispersion.
2. **Circular waveguide** has higher power handling capability than the rectangular one.
3. **Planar waveguide** has a smaller loss than metallic waveguide at high frequency.
4. **Optical fibre** has wider bandwidth and provides good signal isolation between adjacent fibers.

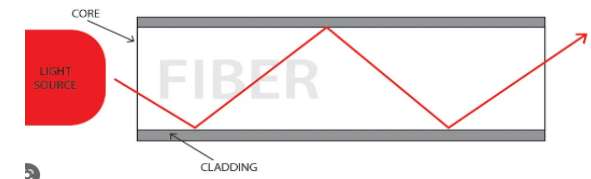
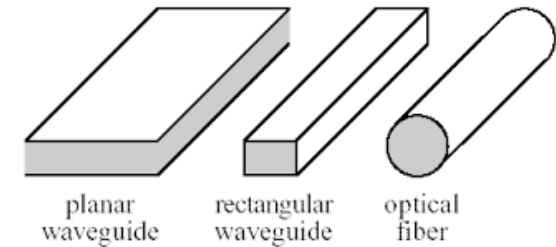

RECTANGULAR WAVEGUIDE FUNDAMENTALS

1. Propagation is in the $+z$ direction.
2. The interior dimensions are “ $a \times b$ ”, the longer side is “ a ”.
3. Higher modes have higher attenuation and be difficult to extract from the guide.
4. In practice, “ b ” is chosen to be about “ $a/2$ ”
5. If “ b ” is increased beyond “ $a/2$ ”, the next mode will be excited at a lower frequency, thus decreasing the useful frequency range.

“ b ” affects attenuation; smaller “ b ” has higher attenuation.

Brass, copper or aluminum conducting wall electroplated with silver or gold on the inside and smoothly polished to reduce loss.

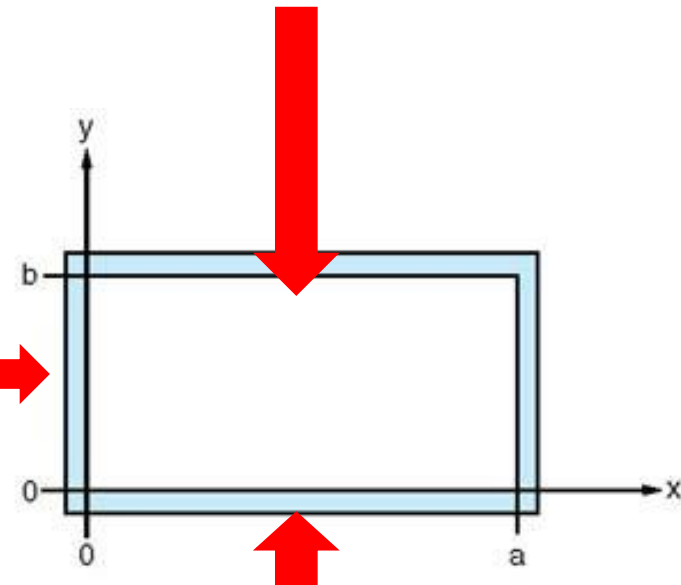

“ a ” determines the frequency range of the dominant, or lowest order mode.

RECTANGULAR WAVEGUIDE FUNDAMENTALS

1. Waveguides support Transverse Electric (TE) and Transverse Magnetic (TM) modes.
2. The order of the mode refers to the field configuration in the guide and is given by “m” and “n” integer subscripts, as TE_{mn} and TM_{mn} .
3. The “m” subscript corresponds to the number of half-wave variations of the field in the x direction.
4. The “n” subscript is the number of half-wave variations in the y direction.
5. “m” and “n” determines the cutoff frequency for a particular mode.
6. **Cutoff frequency, f_c** of a waveguide is the lowest frequency at which a wave can propagate through it

$$f_{c_{mn}} = \frac{1}{2\sqrt{\mu\varepsilon}} \sqrt{\left(\frac{m}{a}\right)^2 + \left(\frac{n}{b}\right)^2}$$

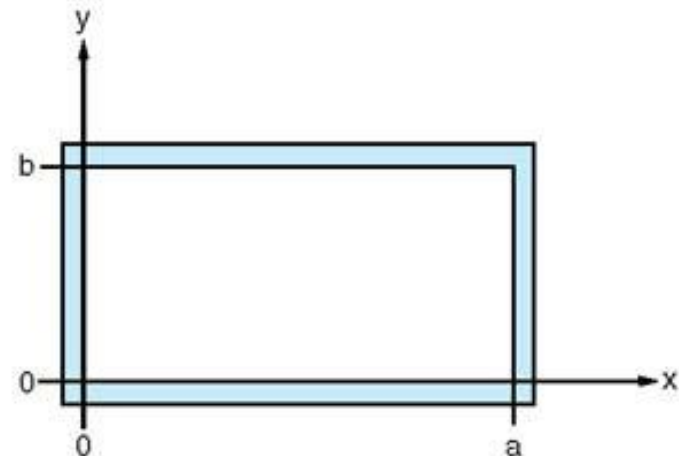

WAVEGUIDE MODES /01

1. Electromagnetic waves traveling through a waveguide follow different patterns, known as modes.
2. There are two principal modes:
 - a) **Transverse Electric (TE)** where the electric field is entirely transverse, i.e., perpendicular to the direction of propagation. There is no electric field component in the direction of propagation.
 - b) **Transverse Magnetic (TM)** where magnetic field is entirely transverse, and there is no magnetic field component in the direction of propagation.

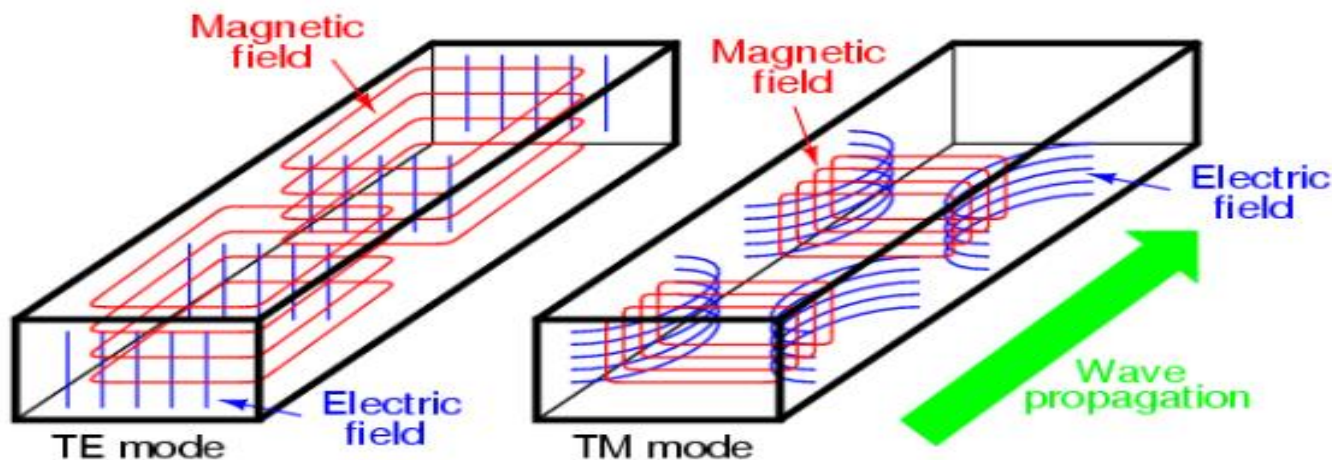

WAVEGUIDE MODES /02

1. Waveguides can support multiple modes with each mode having a different minimum cutoff frequency below which the wave does not pass through the waveguide.
2. The modes are designated as TE_{mn} or TM_{mn} .
3. The numerical subscripts m and n denote the number of half-wave variations in the electric field across the waveguide's cross-section along the x and y directions respectively.

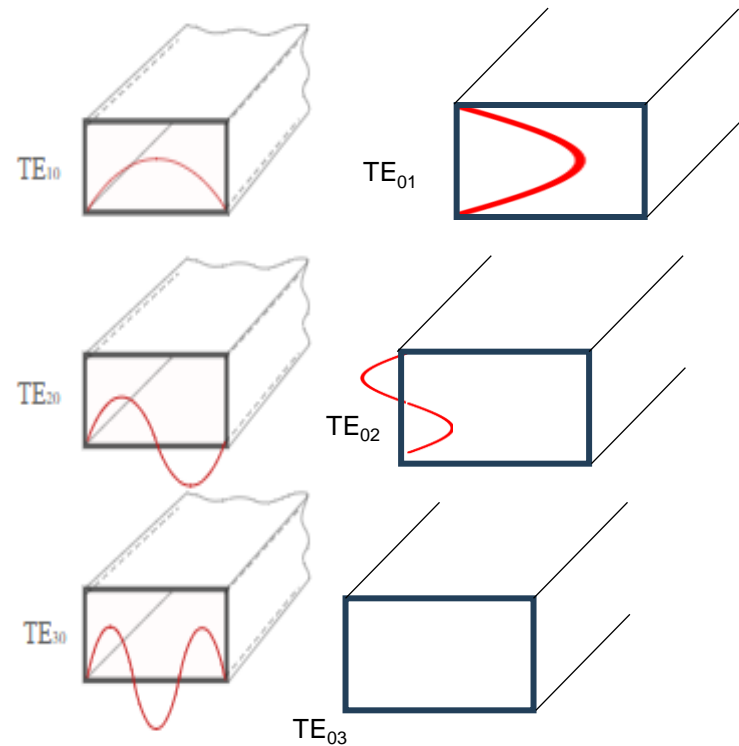

THE RELATIVE CUTOFF FREQ FOR THE FIRST 10 MODES WITH $a = 2b$

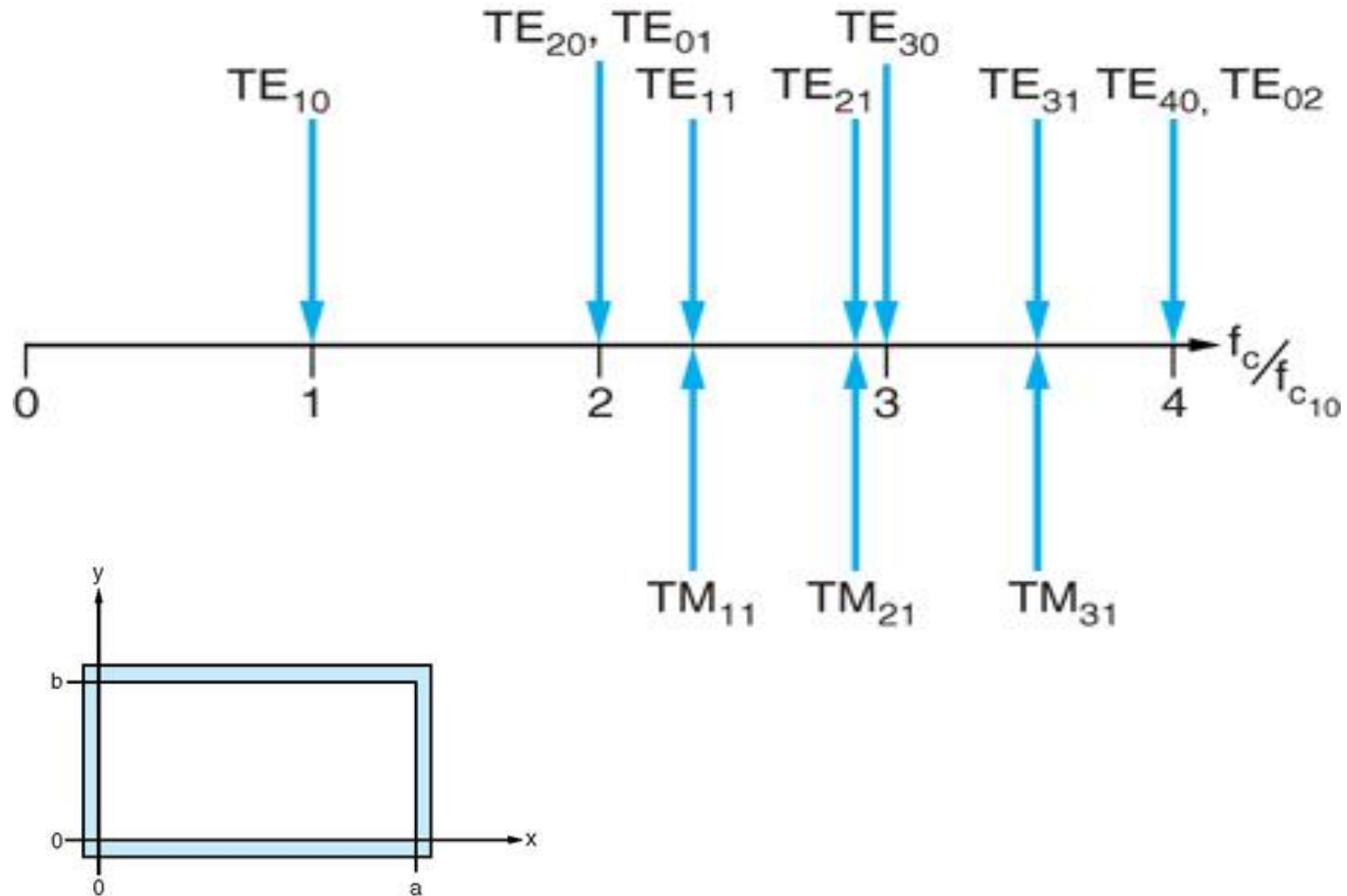

TRANSVERSE ELECTRIC (TE) MODES IN RECTANGULAR WAVEGUIDE

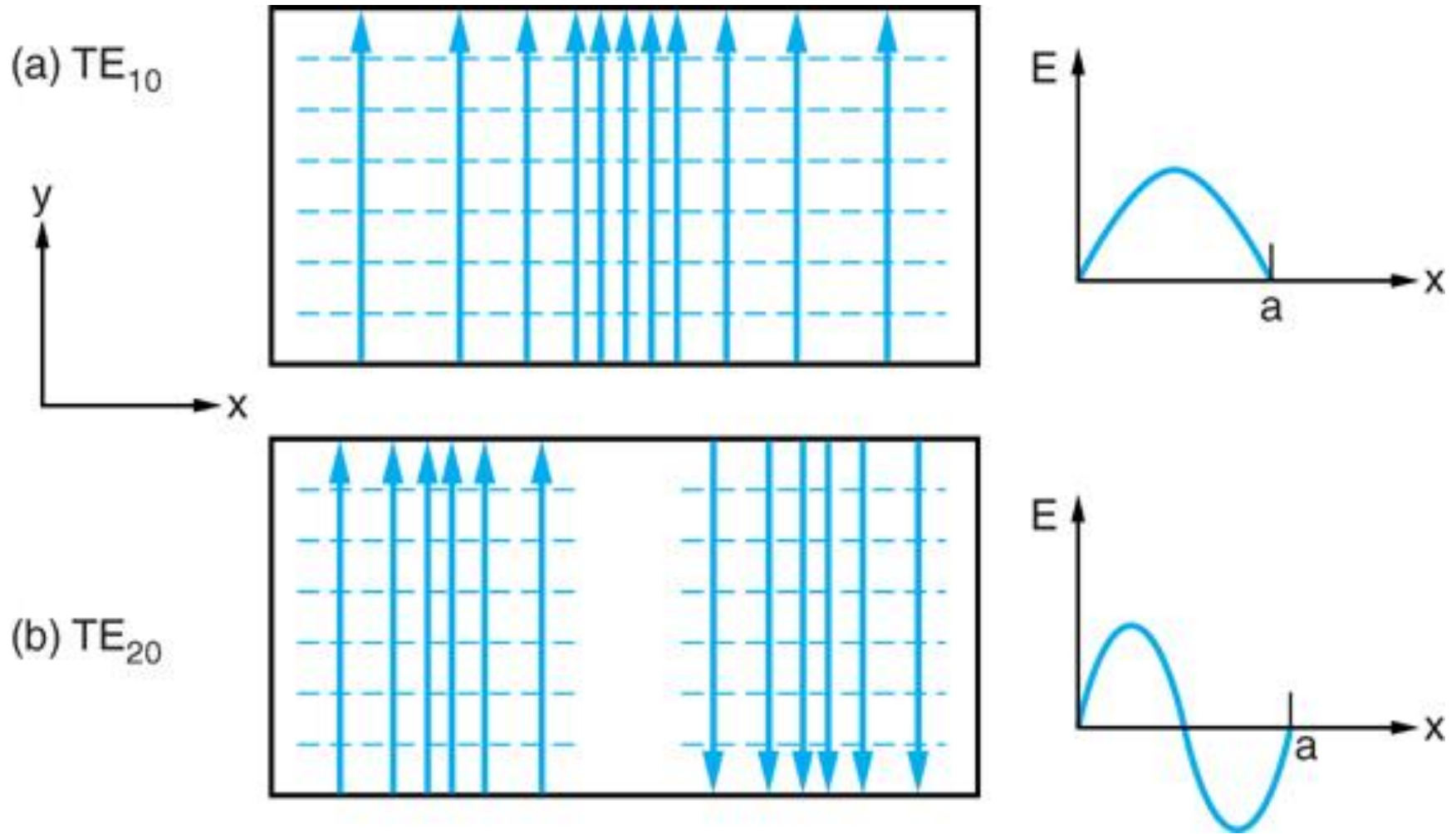

STANDARD WAVEGUIDE SIZES

Waveguide designation	a (in)	b (in)	t (in)	$f_{c_{10}}$ (GHz)	Frequency range (GHz)
WR975	9.750	4.875	0.125	0.605	0.75–1.12
WR650	6.500	3.250	0.080	0.908	1.12–1.70
WR430	4.300	2.150	0.080	1.375	1.70–2.60
WR284	2.840	1.340	0.080	2.08	2.60–3.95
WR187	1.872	0.872	0.064	3.16	3.95–5.85
WR137	1.372	0.622	0.064	4.29	5.85–8.20
WR90	0.900	0.400	0.050	6.56	8.2–12.4
WR62	0.622	0.311	0.040	9.49	12.4–18

Further Reading:

[Waveguide Sizes | Dimensions & Cutoff Frequency - everything RF](#)

SUMMARY: APPLICATIONS OF WAVEGUIDES

1. **Waveguides are used as transmission lines** in applications where it is necessary to carry high power at microwave frequencies (transmitters and microwave ovens) or where it is necessary to carry signals for distances (fibre optic communication).
2. **The following are examples of applications of waveguides.**
 - a) Radar transmitters for civilian and military applications
 - b) Satellite earth station transmitters
 - c) NMR machines in medicine
 - d) Particle accelerators
 - e) Industrial and domestic microwave ovens.