

# MICROWAVE ANTENNAS

EEEN 566 – MICROWAVE ENGINEERING

Friday, 27 March 2026

# WHAT ARE RADIO WAVES? (RECAP)

1. Radio waves are electromagnetic waves of wavelength  $10^{-3}\text{m}$  and higher.
2. Their frequency range is from a few kHz to nearly a 300 GHz.
3. The propagation of radio waves through the atmosphere is relevant in all modern forms of communication: radio, television, mobile, satellite, etc.

Band	Frequency range	Wavelength range
Extremely low frequency (ELF)	< 3 kHz	>100 km
Very low frequency (VLF)	3 - 30 Hz	10 - 100 km
Low frequency(LF)	30 - 300 kHz	1 - 10 km
Medium frequency (MF)	300 kHz - 3 MHz	100m - 1km
High frequency (HF)	3 - 30 MHz	10 - 100m
Very high frequency (VHF)	30 - 300 MHz	1 - 10m
Ultra high frequency (UHF)	300 MHz - 3 GHz	10cm - 1m
Super high frequency (SHF)	3 - 30 GHz	1 - 10cm
Extremely high frequency (EHF)	30 - 300 GHz	1mm - 1cm

# COMMON RADIO FREQUENCY BANDS (RECAP)

The most common applications of radio waves are radio, TV and mobile communication as follows:

- Long Wave Radio: 30 – 300 KHz
- AM Radio: 535-1605 kHz.
- Short Wave Radio: 2.3 – 26.1 MHz
- FM Radio: 88 – 108 MHz
- Television: 470 – 840 MHz
- Cellular Mobile Communication: 880 – 960 MHz (900 MHz band) and 1710 – 1880 MHz (1800 MHz Band), 2100 MHz (3G/WCDMA)

# LONG WAVE RADIO

1. In radio broadcasting, **longwave** refers to parts of the radio spectrum with relatively long wavelengths in the range 1km – 10 km (30 – 300 KHz).
2. The name long wave is historic dating from the early 20th century, when the radio spectrum was divided into three bands, i.e
  - a) Long (LW),
  - b) Medium (MW)
  - c) Short (SW)

# MEDIUM WAVE RADIO FREQUENCY BAND (RECAP)

## ITU Region 1:

- 526.5–1606.5 kHz with 9 kHz spacing.

## ITU Region 2:

- 525–1705 kHz with 10 kHz spacing, including the ITU Extended AM broadcast band.

## Region 3:

- 526.5–1606.5 kHz with 9 kHz spacing.

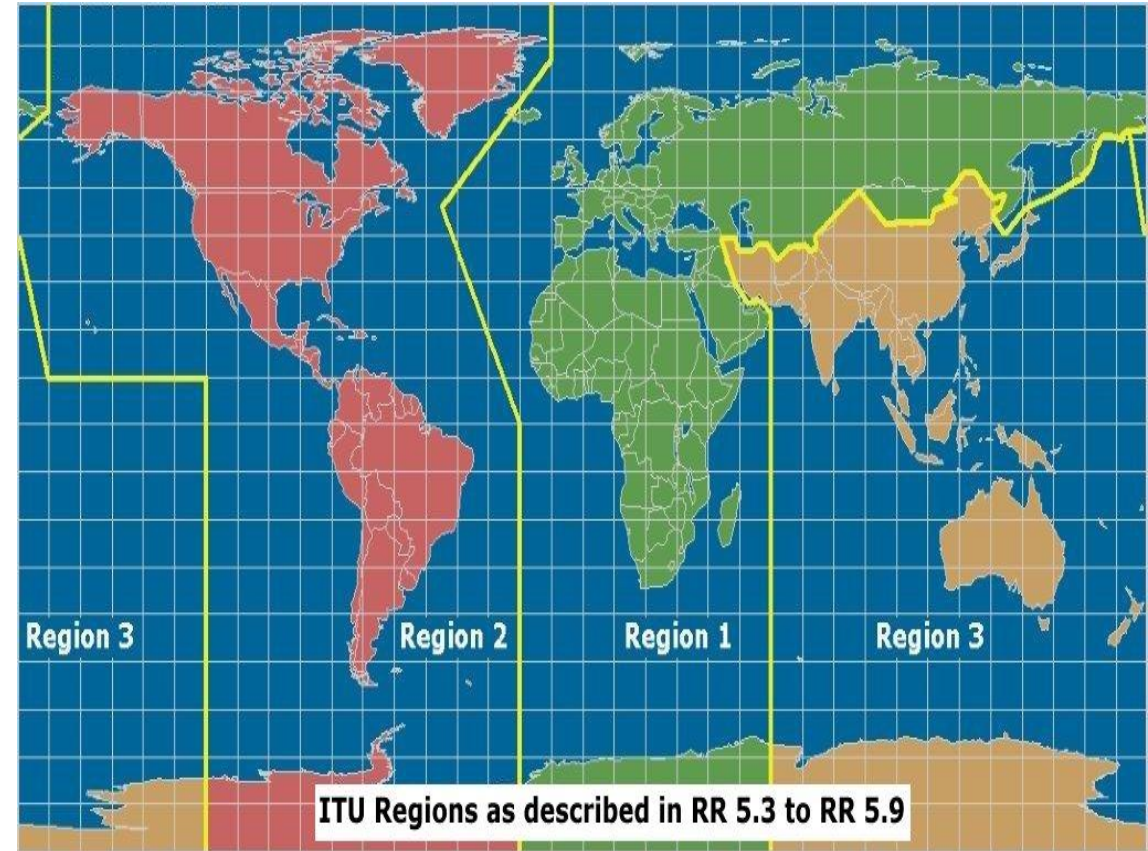

# SHORTWAVE RADIO FREQUENCY BANDS (RECAP)

WAVELENGTH	FREQUENCY	REGIONS WHERE USED
<u>120 metres</u>	<u>2,300-2,495</u> kHz	Only used in tropical areas.
<u>90 metres</u>	<u>3,200-3,400</u> kHz	Only used in Americas.
<u>75 metres</u>	<u>3,900-4,000</u> kHz	Used in Europe, Africa and the Middle East.
<u>60 metres</u>	<u>4,750-4,995</u> kHz	Only used in tropical areas.
<u>11 metres</u>	<u>25,670-26,100</u> kHz	Little activity other than tests of local digital services.

# SUMMARY RADIO BROADCAST FREQUENCY BANDS & CAPACITIES

10 kHz bandwidth from  
540-1600 kHz for  
106 possible bands

200 kHz bandwidth from  
88.1-108.1 MHz for  
100 possible bands

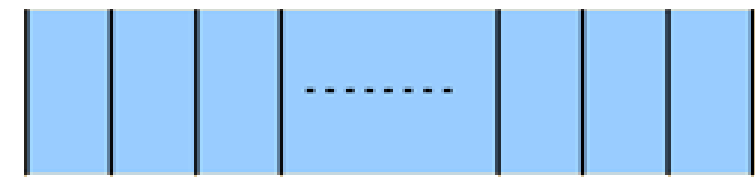
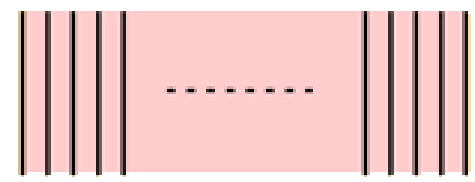

AM

FM

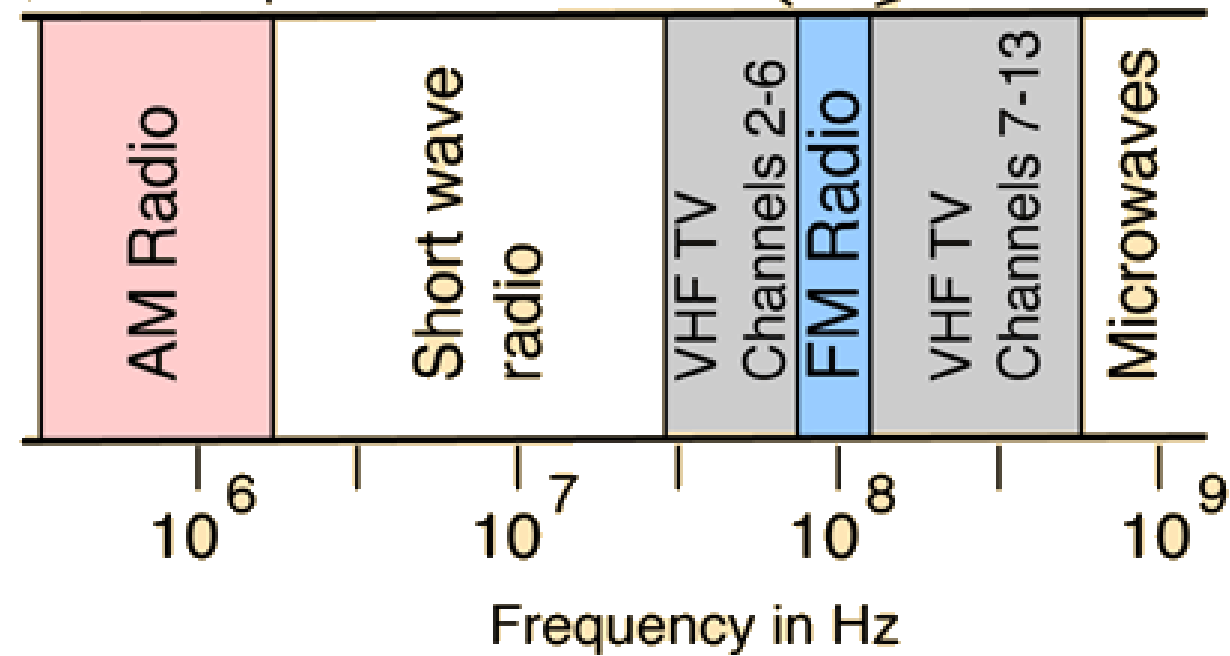

# MICROWAVE FREQUENCY BANDS /01

1. **Microwaves** are Ultrahigh(UHF), Super High (SHF) and Extremely High (EHF) frequencies in the frequency range 0.3 – 300 GHz.
2. The most used microwave range is 1 – 30 GHz. In this range the wavelength varies from 30cm to 1 cm
3. **The L band** is in the UHF band (300MHz – 3,000 MHz).
4. **Part of the S band** is also in the UHF band.
5. Early wireless communication systems were mostly below 300 MHz (radio, TV and navigation applications).
6. Over years, the spectrum below 300MHz became fully utilized leading to most new services being shifted to the microwave frequency range as technology has improved.

BAND DESIGNATION	FREQUENCY RANGE
L Band	1 – 2 GHz
S Band	2 – 4 GHz
C Band	4 – 8 GHz
X Band	8 – 12 GHz
Ku Band	12 – 18 GHz
K Band	18 – 27 GHz
Ka Band	27 – 40 GHz
U Band	40 – 60 GHz

# MICROWAVE FREQUENCY BANDS /02

LETTER DESIGNATION	FREQUENCY RANGE	WAVELENGTH RANGE
<a href="#"><u>L band</u></a>	1 to 2 GHz	15 cm to 30 cm
<a href="#"><u>S band</u></a>	2 to 4 GHz	7.5 cm to 15 cm
<a href="#"><u>C band</u></a>	4 to 8 GHz	3.75 cm to 7.5 cm
<a href="#"><u>X band</u></a>	8 to 12 GHz	2.5 cm to 3.75 cm
<a href="#"><u>Ku band</u></a>	12 to 18 GHz	16.7 mm to 25 mm
<a href="#"><u>K band</u></a>	18 to 26.5 GHz	11.3 mm to 16.7 mm
<a href="#"><u>Ka band</u></a>	26.5 to 40 GHz	5.0 mm to 11.3 mm
<a href="#"><u>Q band</u></a>	33 to 50 GHz	6.0 mm to 9.0 mm
<a href="#"><u>U band</u></a>	40 to 60 GHz	5.0 mm to 7.5 mm
<a href="#"><u>V band</u></a>	50 to 75 GHz	4.0 mm to 6.0 mm
<a href="#"><u>W band</u></a>	75 to 110 GHz	2.7 mm to 4.0 mm
<a href="#"><u>F band</u></a>	90 to 110 GHz	2.1 mm to 3.3 mm
<a href="#"><u>D band</u></a>	110 to 170 GHz	1.8 mm to 2.7 mm

# GENERAL FEATURES OF MICROWAVES

## Below 30 MHz.

1. Conventional components, i.e resistor, inductors and capacitors are easy to realize
2. Circuit analysis uses voltage or current relationships
3. Transit time, i.e time it takes for current carriers (holes or electrons) to move through a device can be neglected.
4. The signals are reflected by the ionosphere
5. Circuit analysis is simpler

## Microwaves:

1. Conventional components, i.e resistor, inductors and capacitors are difficult to realize
2. Analysis uses electric and magnetic fields (wave analysis).
3. Power measurements are more common than voltage and current measurements
4. Transit time forms a high percentage of the signal period.
5. The signals travel in straight line and penetrate the ionosphere
6. Circuit analysis is more complex.

# EQUIVALENT CIRCUITS OF COMMON COMPONENTS AT MICROWAVE FREQUENCIES

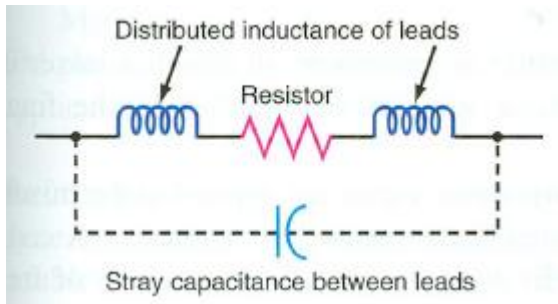

## **(a) Resistor:**

Leads have inductive reactance at high frequency  
Small capacitance exists between the leads

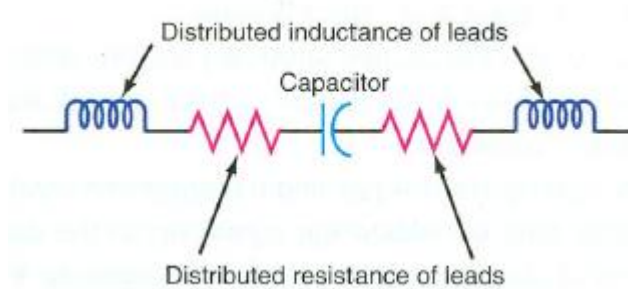

## **(a) Capacitor**

Leads introduce distributed resistance  
Leads introduce distributed inductance

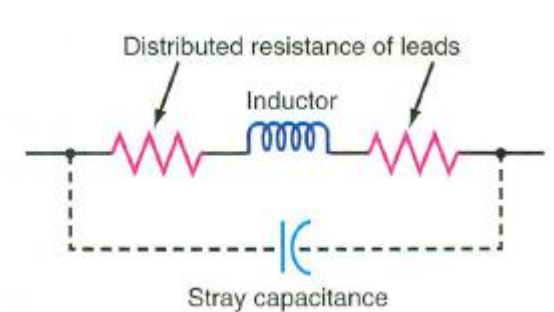

## **(a) Inductor**

Leads introduce stray capacitance  
Leads have distributed resistance

Because of inherent capacitances and inductances, conventional low frequency semiconductor devices such as diodes and transistors malfunction at microwave frequencies.

# WAVEGUIDES

1. Most microwave transmission lines over 3 GHz are waveguides.
2. Waveguides are frequently used to carry a signal from the antenna to the receiver or from the transmitter to the antenna.
3. Waveguides are usually made from copper, aluminium or brass and plated on the inside with silver to reduce resistance – which keeps transmission losses low.



(a) Rectangular waveguide



(b) Circular waveguide

# EXAMPLES OF WAVEGUIDE USE IN ANTENNA ENGINEERING

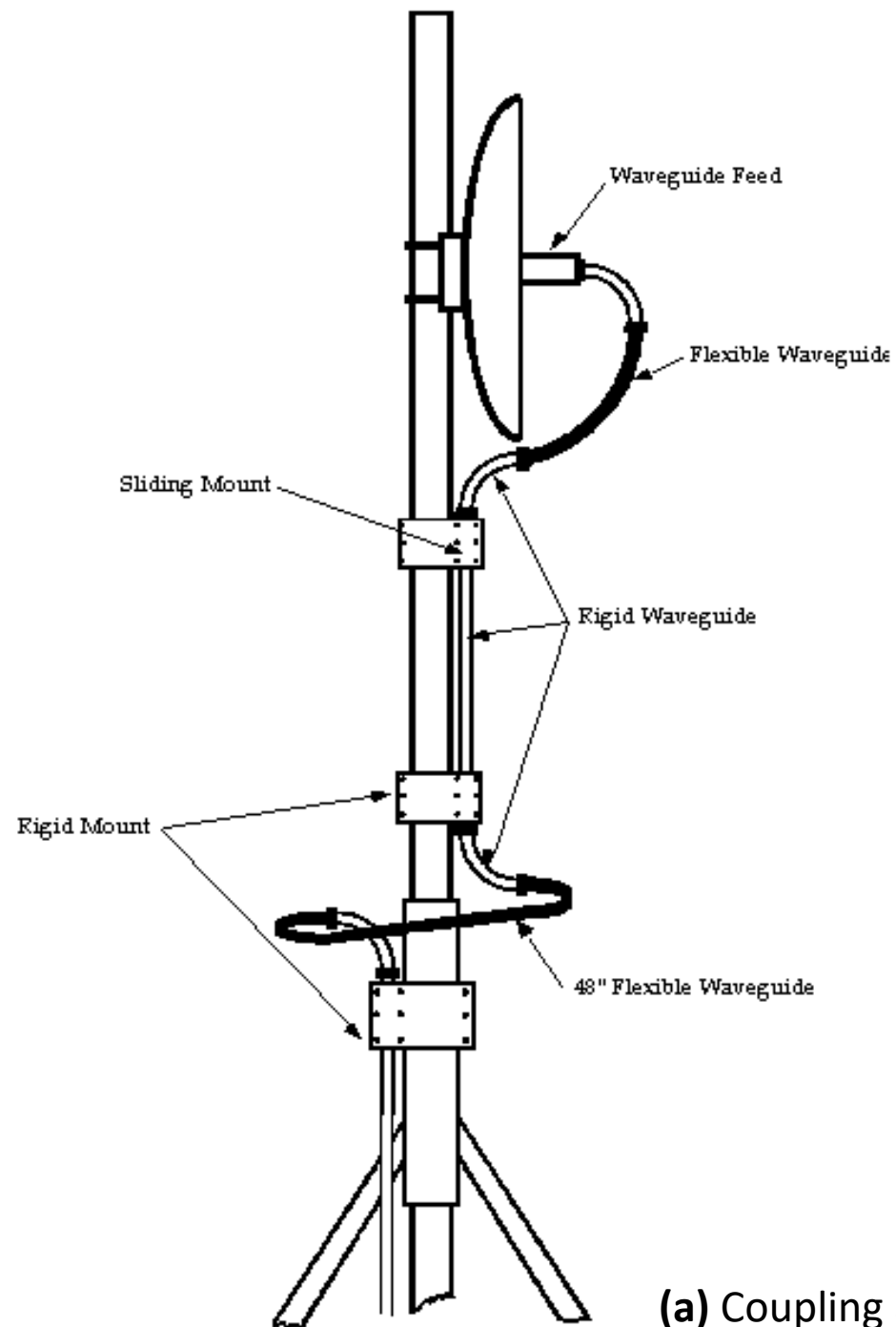

(a) Coupling a transmitter to a dish antenna



(b) Slot Antenna

# ELECTRIC & MAGNETIC FIELDS IN A WAVEGUIDE (REVISITED)

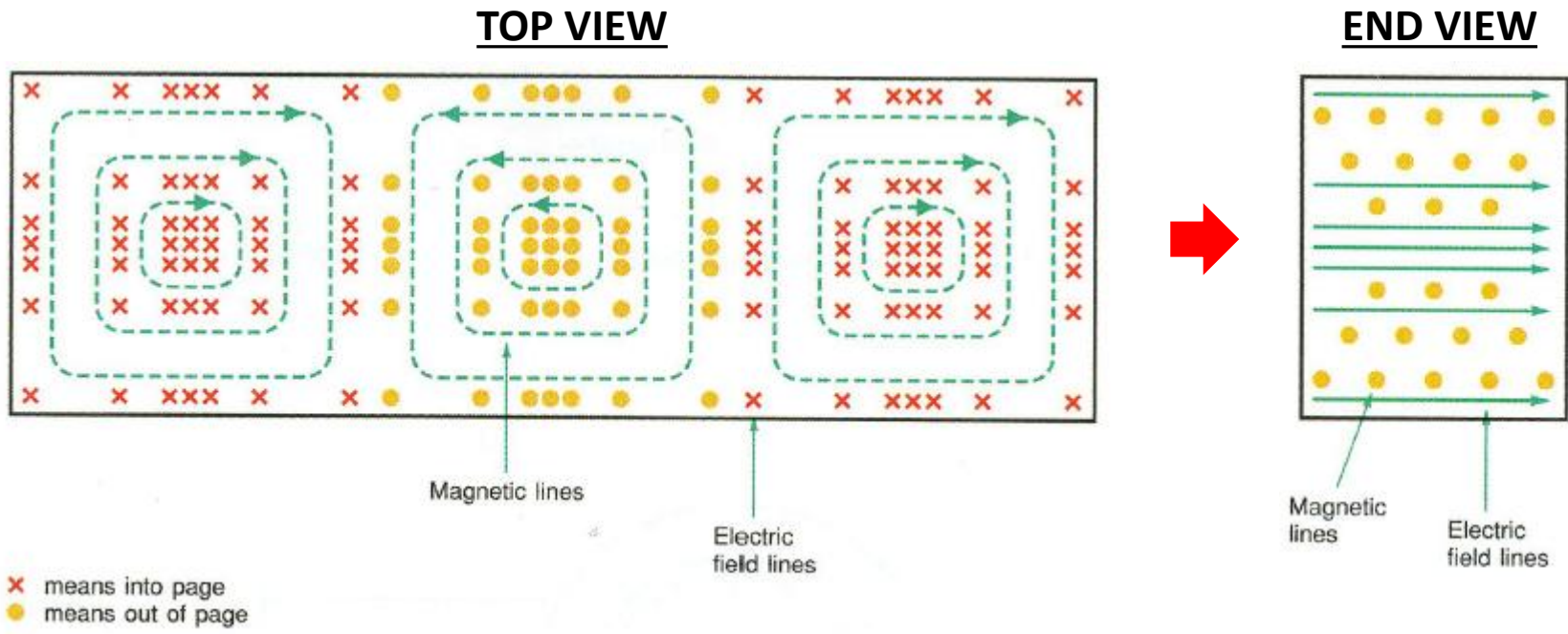

# RECTANGULAR WAVEGUIDE CUT-OFF FREQUENCY

1. Rectangular waveguides can support many modes of transmission.

1. The  $TE_{10}$  mode at the cut-off frequency is the dominant and most commonly used.
2. The waveguide will not transmit energy below the cut-off frequency. The waveguide is therefore sometimes viewed as a high pass filter.
3. The lower cut-off point for a rectangular waveguide is therefore calculated as:

$$f_c = \frac{c}{2a}$$

where:

- $f_c$  = rectangular waveguide cut off frequency in Hz
- $c$  = speed of light within the waveguide in metres per second
- $a$  = the large internal dimension of the waveguide in metres

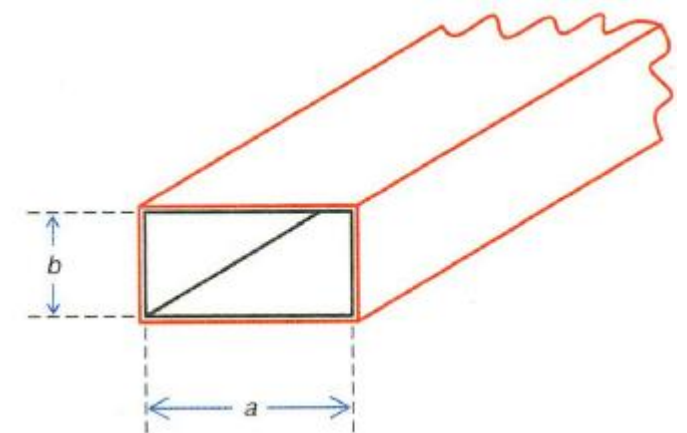
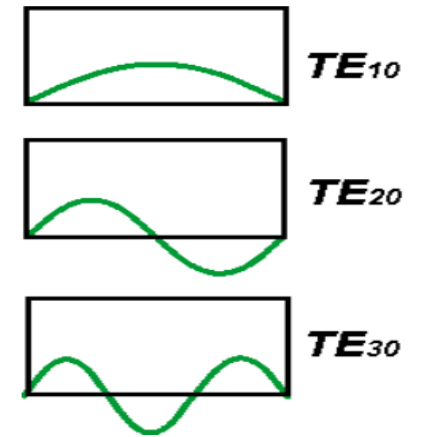

# OPERATING FREQUENCY OF A WAVEGUIDE

- The accepted limits of operation for rectangular waveguide are (approximately) between 125% and 189% of the lower cut-off frequency

# EXAMPLE

A rectangular waveguide has width of 5 cm and a height of 3 cm.

- (a) What is the cut-off frequency of this waveguide?
- (b) What is the typical operating frequency of this waveguide?
- (c) Can this waveguide operate in the L-band?

## SOLUTION

(a) The width,  $a = 0.05\text{m}$

$$\text{Cutoff frequency, } f_{ca} = \frac{3 \times 10^8}{0.1} = 3 \times 10^9 = 3 \text{ GHz}$$

(b) Let the operating frequency be,  $f_o$  and above

$$\text{Then } 1.25f_{co} \leq f_o \leq 1.89f_{co} \quad 3.75 \leq f \leq 5.67$$

(c) The L band is 1-2 GHz

The waveguide can only pass signals of 3 GHz and above and therefore will not pass an L-band signals.

# WHY SPECIAL MICROWAVE ANTENNAS ARE REQUIRED

1. The dipole and its variants (bow-tie, Yagi, etc.) which have been introduced in the previous classes are usually used at frequencies less than 3 GHz.
2. Although the dipole and its variants can be used at higher microwave frequencies, their dimensions become extremely small. They therefore radiate energy inefficiently.
3. Because microwaves only move in straight line, highly directive antennas are required to increase gain and therefore increase the signal to noise ratio at the receiver.
4. Special high-gain antennas are therefore used in microwave applications.

## EXAMPLE

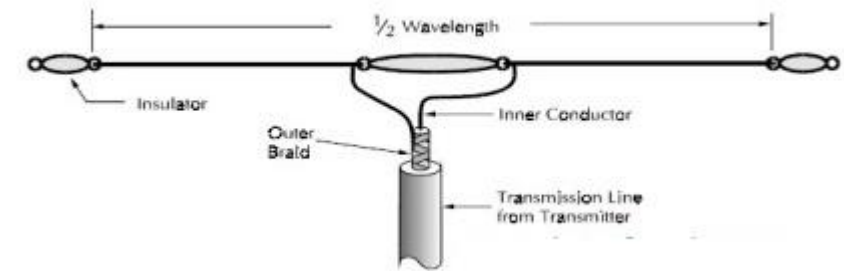

### Size of Dipole at Microwave Frequency

$$\text{At 6GHz, } \lambda = \frac{3 \times 10^8}{6 \times 10^9} = 5 \text{ cm}$$

$$\text{(a) Dipole length} = \frac{\lambda}{2} = 2.5 \text{ cm}$$

$$\text{(b) Monopole length} = \frac{\lambda}{4} = 1.25 \text{ cm}$$

# HORN ANTENNA

1. Waveguides can be made efficient radiators of energy by flaring one end to create a horn antenna.
2. The resulting horn antenna provides high gain and directivity.
3. Usually, the longer the horn, the higher the gain and directivity.

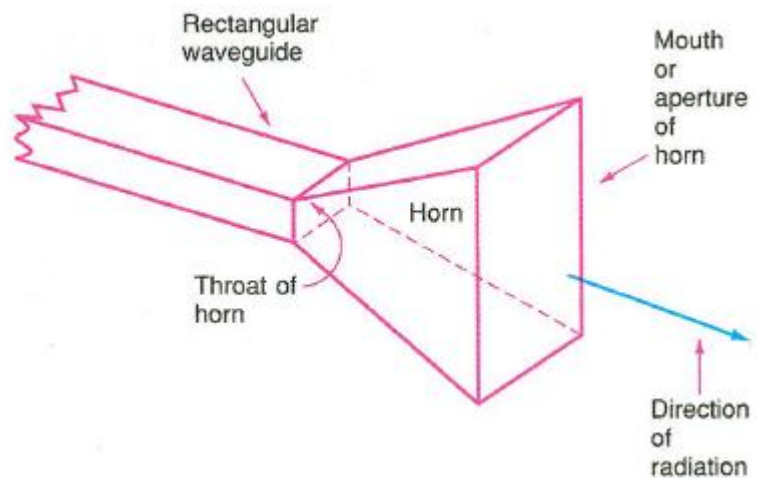

# PARAMETERS OF A HORN ANTENNA

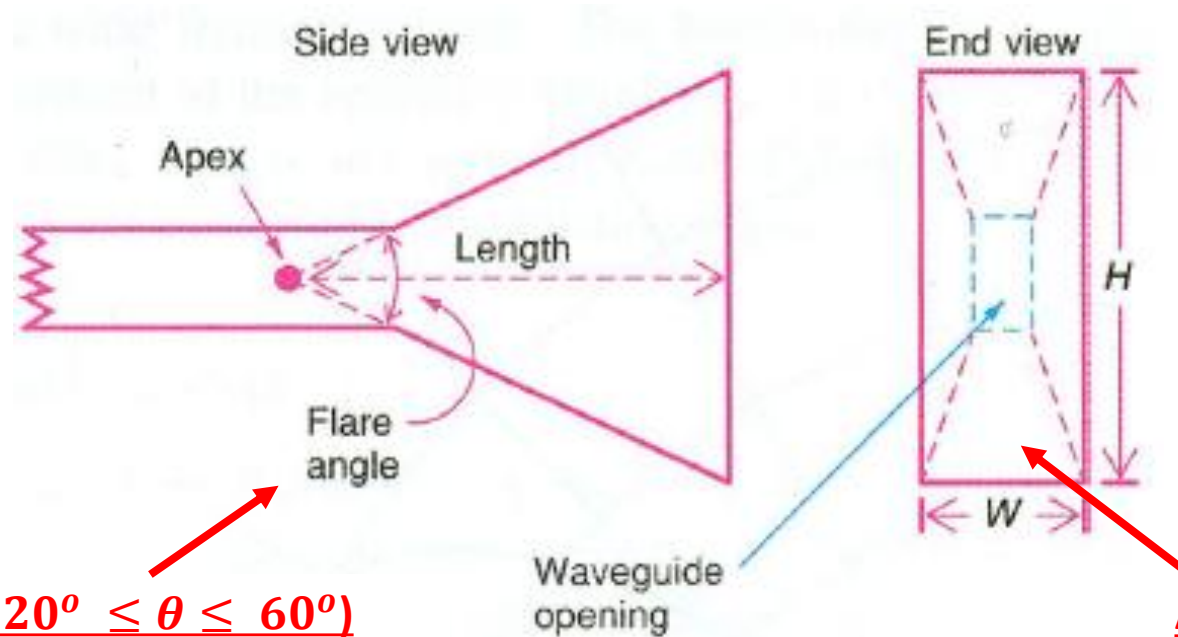

**Flare Angle ( typical  $20^\circ \leq \theta \leq 60^\circ$  )**

Affects the gain and directivity  
Increasing the flare angle increases the aperture

**Aperture,  $A = H \times W$**

The greater the Aperture, the greater the gain and directivity

# TYPES OF HORN ANTENNA – PYRAMID HORN

1. The **pyramid horn** antenna takes on a rectangular shape - the cross section through the antenna is rectangular, as is the end of the antenna.
2. **Pyramid Horn** is normally used with rectangular waveguide.

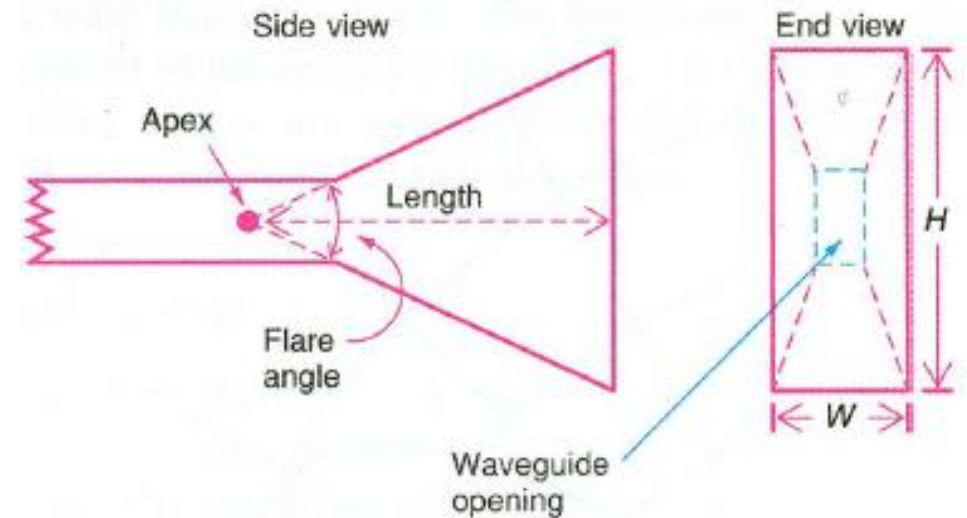

## Pyramid Horn

The width and height of the pyramid Horn are higher than those of the waveguide

# TYPES OF HORN ANTENNA – SECTORAL HORN

1. The Sectoral horn antenna is one in which only one pair of sides flared whilst the other remains parallel to the corresponding edge of the waveguide.
2. The configuration produces a fan-shaped beam, which is narrow in the plane of the narrow sides, but wide in the plane of the flared sides.
3. There are two types of sectoral horns, i.e
  - a) **E-plane horn antenna:** A horn that is flared in the direction of the electric or E-field in the waveguide.
  - b) **H-plane horn antenna:** A horn that is flared in the direction of the magnetic or H-field in the waveguide.

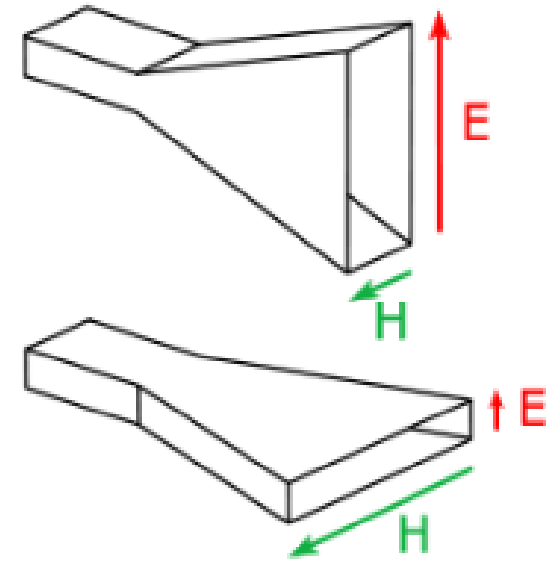

## Sectoral Horn

One dimension of the aperture is the same as that of the waveguide

# TYPES OF HORN ANTENNA – CONICAL HORN

1. **The conical horn antenna is shaped in the form of a cone, with a circular cross section.**
2. **Conical Horn** is normally used with circular waveguide and is therefore used less frequently than the rectangular version.

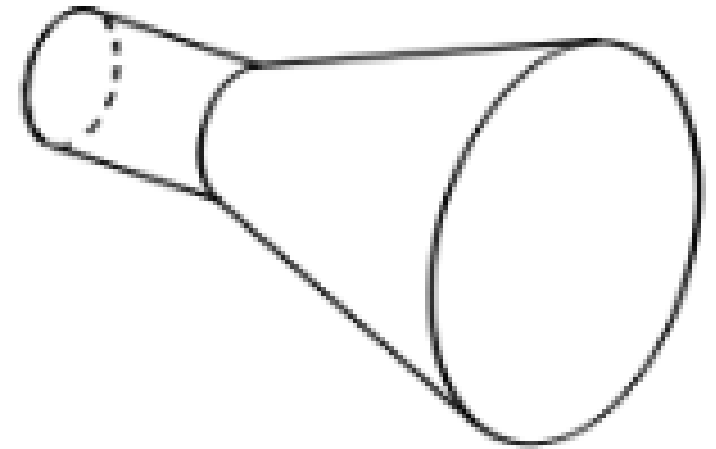

# BEAMWIDTH OF A HORN

1. **The beam width of a horn antenna** is the angle formed by extending lines from the centre of the main lobe to the 3-dB down points.
2. The beam width for a horn antenna is usually given by the expression:

$$B = \frac{80}{W/\lambda} = \frac{80\lambda}{W}$$

Where

$W$  = horn width

$\lambda$  = the wavelength of the operating frequency

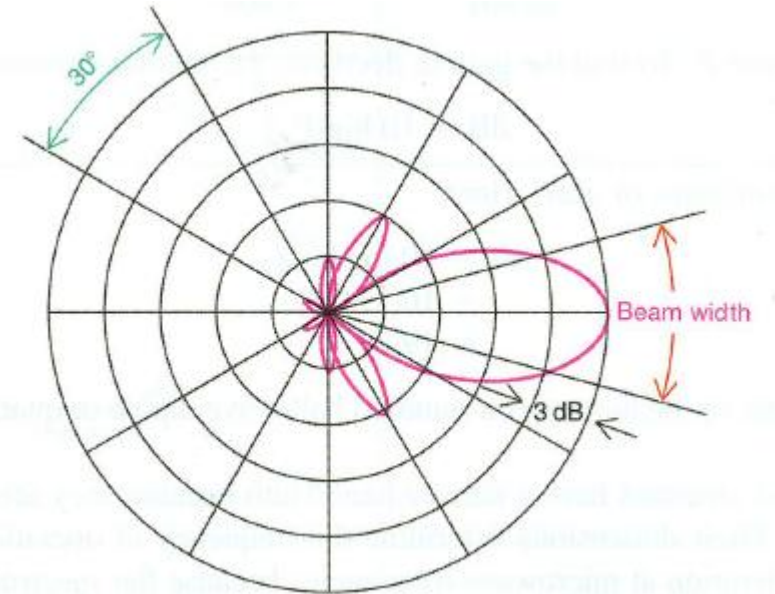

(a) Typical plot of the radiation pattern of a horn antenna

# GAIN OF HORN ANTENNA

The gain of a pyramidal horn antenna is given by:

$$G = 4\pi \frac{kA}{\lambda^2}$$

Where

$A$  = Aperture of Horn in  $m^2$

$\lambda$  = wavelength

$k$  is a constant that varies from 0.5 – 0.6

# BANDWIDTH OF A HORN ANTENNA

1. Unlike other antennas which are resonant and therefore operate at a single frequency, **horns are non-resonant and therefore operate at a wide frequency range.**
2. The bandwidth of a horn is usually approximated as 10% of the operating frequency.
3. For example, the bandwidth of a horn operating at 12.5 GHz is 1.25GHz. This is enormous bandwidth which can accommodate any kind of complex modulating signal.

# ADVANTAGES OF HORN ANTENNA

The following are the advantages of the horn antenna:

- 1. Wide bandwidth:** The horn antenna possesses no resonant elements and therefore it is able to operate over a wide bandwidth.
- 2. Simple construction:** The horn antenna consists simply of a flared horn. As a result they are relatively easy to construct.
- 3. Easy interface to waveguide:** By the very nature of their shape, these antennas are very easy to interface to waveguide, although they can also be designed with a transition to link with a standard coaxial feeder.

# PARABOLIC ANTENNAS

1. **A microwave parabolic antenna** is usually a combination of a horn antenna and a dish used to provide higher gain and directivity.
2. The energy radiated by the horn is pointed to the reflector which focuses the radiated energy into a narrow beam.
3. **Beam-widths** of a few degrees are typical with parabolic antennas.
4. The dish can also be used to focus the received energy to another horn antenna used as a receiver.

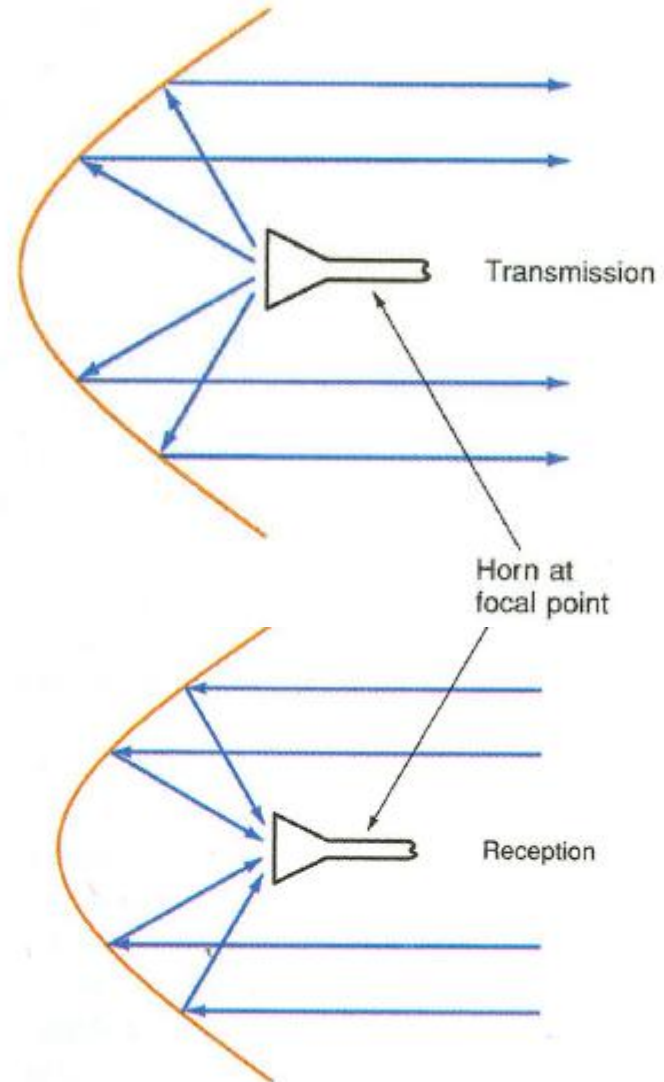

# GAIN OF A PARABOLIC ANTENNA

The gain of a parabolic antenna is given by the expression:

$$G = 10 \log_{10} k \left( \frac{\pi D}{\lambda} \right)^2$$

Where

G = gain expressed as a power ratio

D is the diameter of the dish in metres

$\lambda$  is the wavelength in metres

K is the efficiency factor given by  $0.5 \leq k \leq 0.6$

# BEAM WIDTH OF A PARABOLIC ANTENNA

The beam width,  $B$  of a parabolic antenna is estimated by the expression

$$B = \frac{70}{D/\lambda} = \frac{70\lambda}{D}$$

Where

$B$  = is the beamwidth in degrees

$D$  is the diameter of the dish in metres

$\lambda$  is the wavelength in metres

# PARABOLIC ANTENNA - FEED METHODS

There are many different methods of positioning the horn.

**(a) Focal point feed system:**  
where the source of the radiation is placed at the focal point of the parabola and used to illuminate the reflector.

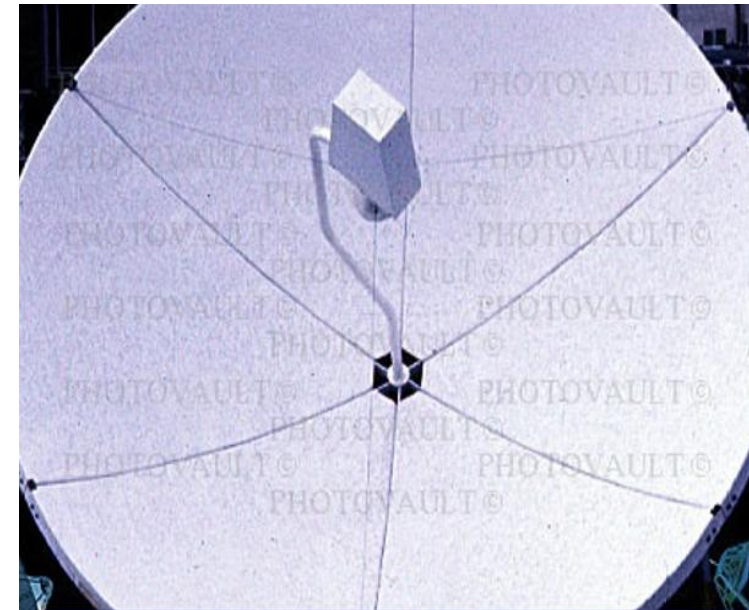
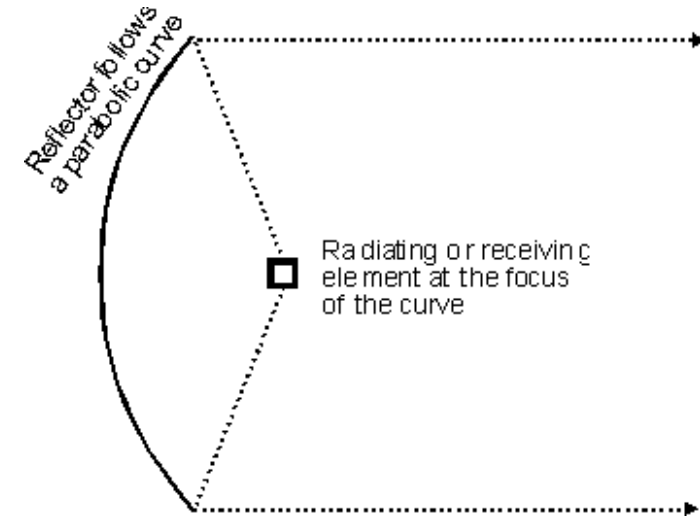

# DUAL REFLECTOR CONVEX SYSTEM (1)

1. The dual-reflector convex (also called **Cassegrain reflector system**) antenna consists of two reflectors and a feed antenna.
2. The feed is conveniently located at the apex of the main reflector which makes the system mechanically robust, i.e the transmission lines are shorter and easier to construct (especially when waveguides are used).

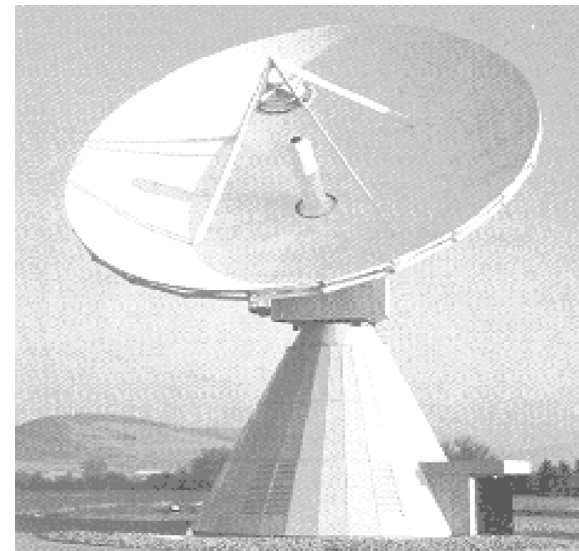
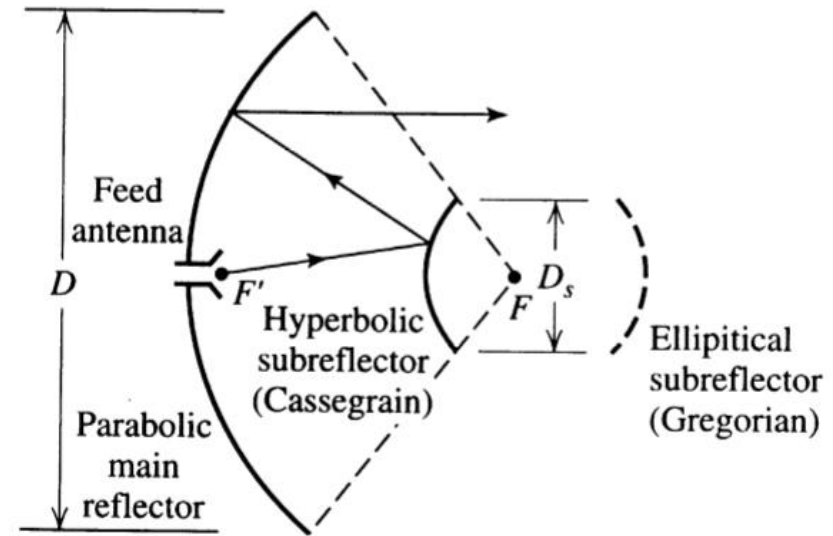

# DUAL REFLECTOR CONVEX SYSTEM (2)

- The dual-reflector convex or Cassegrain reflector system reflector can be modelled as a single equivalent parabolic reflector as shown.

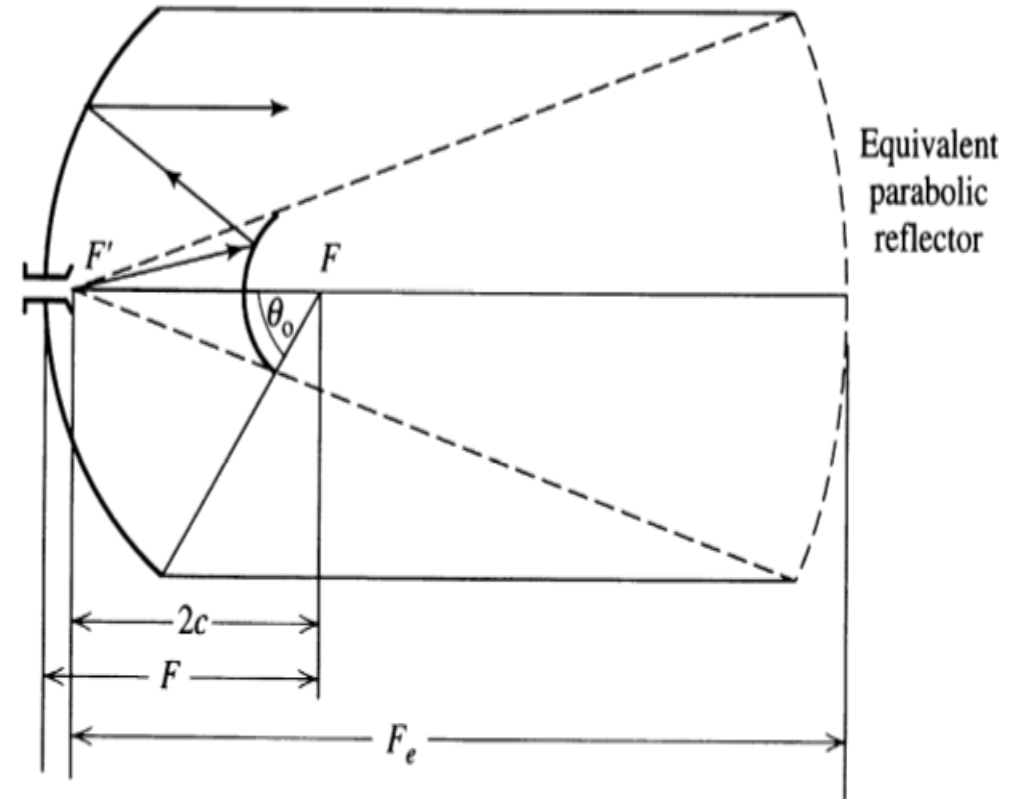

# DUAL REFLECTOR CONCAVE SYSTEM

1. The **dual reflector concave parabolic reflector** feed (also called **Gregorian feed**) technique has a concave secondary reflector.
2. This antenna can achieve aperture efficiency levels of over 70% because the system is able to provide a better illumination of all of the reflector surface.

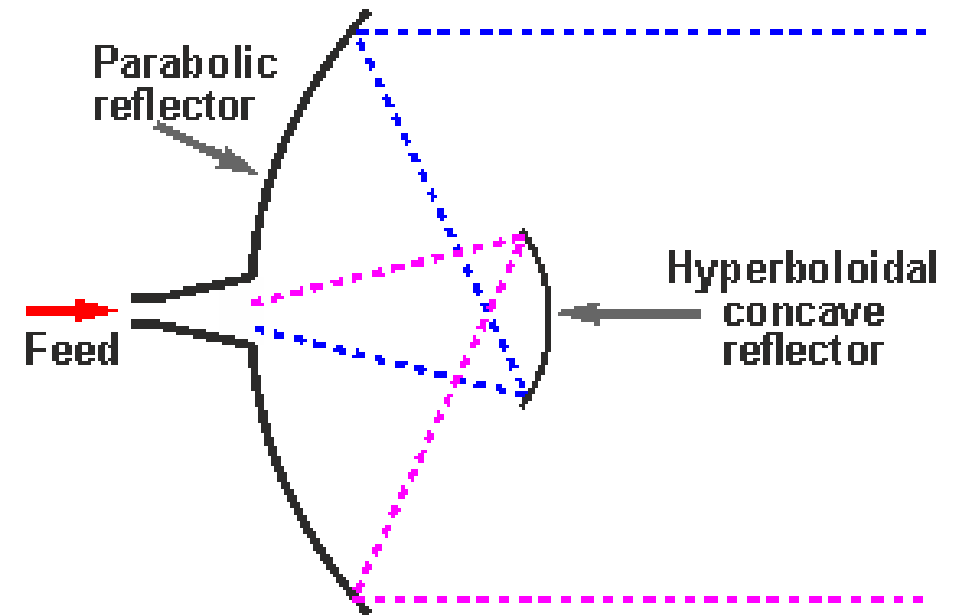

# OFF AXIS OR OFFSET PARABOLIC REFLECTOR PARABOLIC ANTENNA FEED

1. The Off-axis parabolic reflector antenna has a feed that is offset from the centre of the antenna dish.
2. The reflector used in this type of feed system is an asymmetrical segment a parabola. In this way the focus, and the feed antenna are located to one side of the reflector surface.
3. The advantage of using this approach to the feed system is not in the way of beam path thus avoiding blockage.
4. This reflector is widely used in home satellite television antennas, which are relatively small and this would mean that any the feed structure including the low noise box amplifier, would otherwise block a significant percentage of the beam and thereby reduce the antenna efficiency and received signal level.

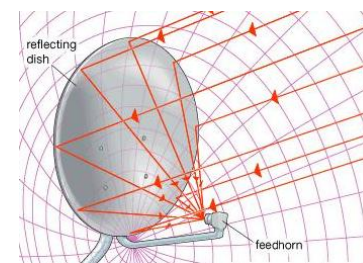
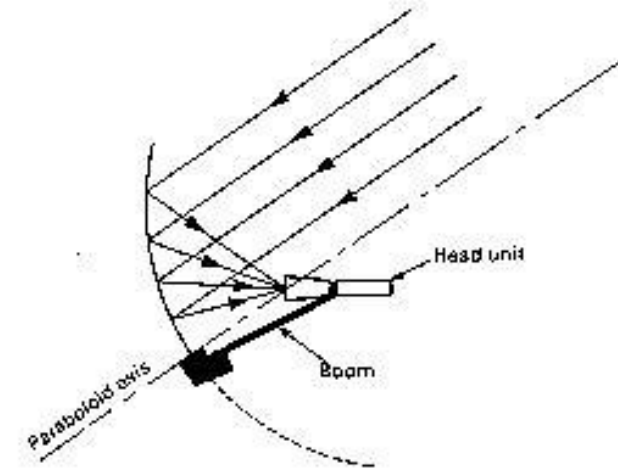

(a) Domestic TV antenna

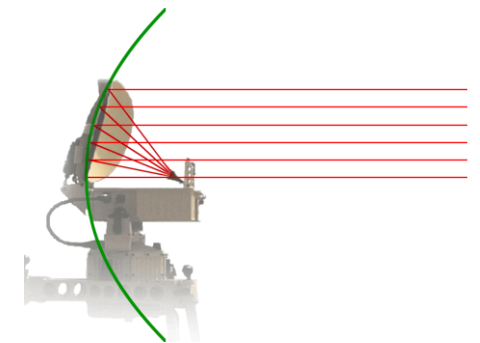

(b) Terrestrial Relay Antenna

# ADVANTAGES OF PARABOLIC ANTENNAS

The advantages of the parabolic reflector antenna are:

1. Ability to provide very high levels of **gain**. The larger the 'dish' in terms of wavelengths, the higher the gain.
2. Ability to provide high levels of **directivity**. The higher the gain, the narrower the beam-width. This can be a significant advantage in applications where the power is only required to be directed over a small area as in radar systems.

# DISADVANTAGES OF PARABOLIC ANTENNAS

- 1. Requires reflector and drive element:** the parabolic reflector itself is only part of the antenna. It requires a feed system to be placed at the focus of the parabolic reflector.
- 2. Cost:** A paraboloid is needed to reflect the radio signals which must be made carefully. In addition to this a feed system is also required. This can add cost to the system
- 3. Size:** The antenna is not as small as some types of antenna, although most of those used for satellite television reception are quite compact.

# SLOT ANTENNA

1. Slot antennas are an about  $\lambda/2$  elongated slot, cut in a conductive plate (Consider an infinite conducting sheet), and excited in the centre.
2. This slot behaves according to **Babinet's principle** as resonant radiator.
3. Babinet's principle relates the radiated fields and impedance of an aperture or slot antenna to that of the field of a dipole antenna.

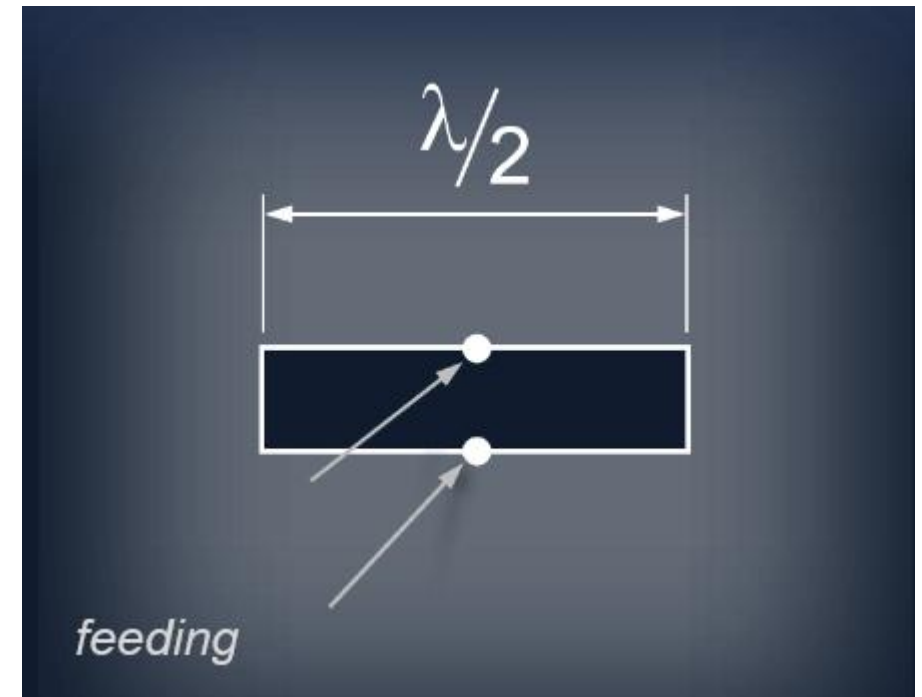

# BABINETS PRINCIPLE

- **Babinet's principle** states that the diffraction pattern from an opaque body is identical to that from a hole of the same size and shape except for the overall forward beam intensity.
- It was formulated in the 1800s by French physicist Jacques Babinet.

# FIELDS OF A SLOT ANTENNA

1. The fields of the slot antenna are almost the same as the dipole antenna, but the field's components are interchanged.
2. A vertical slot has got an horizontal electric field; and the vertical dipole has got a vertical electrical field.
3. The polarization of a slot antenna is linear.

# IMPEDANCE OF A SLOT ANTENNA

- The impedance of the slot antenna ( $Z_s$ ) is related to the impedance of its complementary dipole antenna ( $Z_d$ ) by the relation:

$$Z_d Z_s = \frac{\eta^2}{4}$$

Where

$Z_s$  = impedance of the slot antenna

$Z_d$  = impedance of its dual antenna

$\eta$  = intrinsic impedance of free space.

# APPLICATION OF SLOT ANTENNAS

1. Slot antennas are used typically at frequencies between 300 MHz and 24 GHz
2. They are widely used on aircrafts where external antennas would be torn off at high speed.

